



# Operations Manual

and

# Seal Kit Replacement Guide

MANUFACTURED BY COLUSSI ENGINEERING PTY. LTD.  
TELEPHONE: (02) 9817 5433 FAX: (02) 9879 6753  
53 College street, Gladesville, NSW 2111, Australia  
[www.novapumps.com.au](http://www.novapumps.com.au)

## Warranty Details

Record the details of your Nova Pump and the supplying Dealer for future reference when discussing service, ordering parts or making a warranty claim.

Pump Model      NPP     SPP     SPE

Pump Serial No.      \_\_\_\_\_

Engine Model No.      \_\_\_\_\_ (if fitted)

Engine Serial No.      \_\_\_\_\_ (if fitted)

Supplying Dealer      \_\_\_\_\_

Address      \_\_\_\_\_  
                                 \_\_\_\_\_  
                                 \_\_\_\_\_

Telephone No.      \_\_\_\_\_

Date of Purchase      \_\_\_\_\_



## Safety Information

Before operating the unit read the following safety instructions.

Failure to comply with these warnings may result in serious injury or death.

For specific Safety Information relating to the attached engine or motor ensure you read and understand the manual and instructions supplied by the engine or motor manufacturer.

### DANGER:

- DO NOT pump flammable or explosive fluids such as gasoline, fuel, oil, kerosene etc.
- DO NOT use in explosive atmospheres.
- The pump should be used only with liquids compatible with the pump component materials.
- Never allow an inadequately trained person to operate the unit.
- Ensure the unit is not operated in a confined space. It must be used in an area with adequate ventilation.
- Before the use of any chemicals refer to the chemical manufacturers label and safety instructions for safe handling procedures and correct method of use. Always use the recommended personal protective clothing and safety equipment.
- Check hoses for weak or worn condition before each use and ensure all connections are tight and secure.
- Before servicing, drain all liquids from the system and flush.
- When using the electric model the following fundamental rules apply:
  - Regularly check the switch and hosing for any cracks that may allow the entry of water.
  - Any extension lead used must be rated at 15 amp or greater and not coiled during use.
  - Never use the machine with wet hands or feet
  - Switch the machine off and disconnect the plug prior to undertaking any maintenance operations.

## Warranty Terms

All our pumps are covered against manufacturing defects by a 24 month, non-transferable warranty.

The warranty of engines on all engine-driven equipment and electric motors on electric pumps remains the responsibility of the engine/motor manufacturer respectively. This is subject to the particular terms and conditions set by each manufacturer.

The warranty period commences on the date the equipment is purchased. To validate warranty claims, evidence of this date of purchase will be required.

Nova Pumps undertakes to repair free of charge those parts showing manufacturing defects within the warranty period. Defects not clearly attributable to materials or manufacture will be examined by Nova Pumps and charges may be applicable depending on the results of the examination.

It is the user's responsibility to verify that the chemicals used are compatible with the pump. Users should contact Nova Pumps if in doubt.

This warranty is subject to compliance with the directions and guidelines of use and installation as set out in the User Manual. This warranty does not cover:

- Freight damage
- Normal wear and tear (including seals)
- Damage caused by misapplication, negligence or alterations
- Damage caused by misuse, neglect or inadequate maintenance
- Damage caused when the unit has been allowed to run dry
- Damage caused by freezing liquids
- Damage caused by abrasives in pumped liquids
- Repairs which affect the performance or reliability of the pump

All service under this warranty takes place at the Nova Pumps manufacturing facility. The fee involved in transporting the unit to and from the manufacturer will be done at the customer's expense.

- THIS WARRANTY IS THE ONLY WARRANTY APPLICABLE TO COLUSSI ENGINEERING PTY LTD NEW PRODUCTS AND, TO THE MAXIMUM EXTENT PERMITTED BY LAW, IS EXPRESSLY IN LIEU OF ANY OTHER WARRANTIES EXPRESSED OR IMPLIED, INCLUDING ANY IMPLIED WARRANTY OF MERCHANTABILITY OR FITNESS FOR A PARTICULAR PURPOSE.
- COLUSSI ENGINEERING PTY LTD DOES NOT AUTHORISE ANY PERSON TO CREATE FOR IT ANY OTHER OBLIGATION OR LIABILITY IN CONNECTION WITH THESE PRODUCTS.
- COLUSSI ENGINEERING PTY LTD SHALL NOT BE LIABLE FOR INCIDENTAL OR CONSEQUENTIAL DAMAGES RESULTING FROM A PRODUCT PERFORMING IN BREACH OF THIS WRITTEN WARRANTY.

## Product Information

The Nova Pump is an Australian made, high pressure, spray pump. Built to withstand harsh and aggressive chemicals it is extremely reliable in a demanding environment.

With decades of experience the Nova Pump is a hard working, durable pump that provides consistent performance day after day, spray after spray.

Manufactured from high quality bronze, the Nova Pumps compact and simple design ensures a safe delivery of a wide range of chemicals through its impeller pump system.

The robust and hardwearing construction means your Nova Pump's total lifetime cost of ownership is very low and delivers you excellent value for money.

Nova Pumps are widely used in the pest control, weed control, horticultural and agricultural industries for the purposes of spot spraying, continuous spraying and flooding.

Nova Pumps are used for small and medium applications whenever there is a need to spray harsh or aggressive chemicals in a controlled manner.

The Nova NP Petrol (Non Prime) coupled to the Honda GX160 5.5hp engine delivers a premium spraying performance and has the highest volume in the Nova range.

The Nova SP Petrol (Self Prime) coupled to the Honda GX120 4.0 hp engine provides a heavy duty output and has the benefit of easy on-going operation.

The Nova SP Electric (Self Prime) is powered by a Teco 240V electric motor and delivers industrial strength performance with low maintenance and "whisper" quiet operation.

## Product Performance Graphs

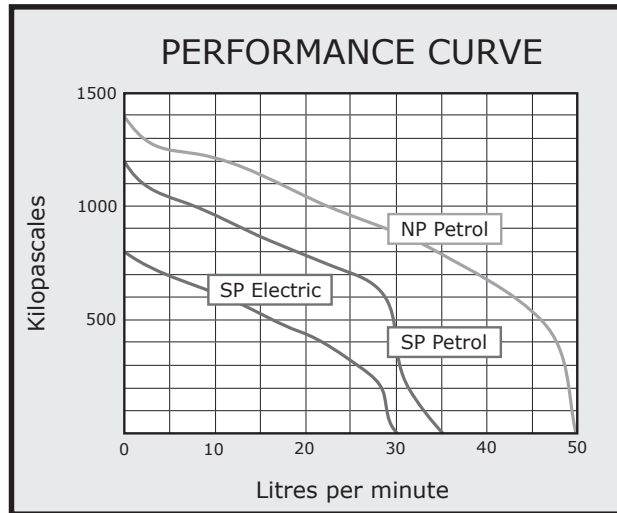

Performance at pump

All figures are indicative only and results may vary between units.

## Nova Pump Specifications

Model	Nova NP Petrol	Nova SP Petrol	Nova SP Electric
Engine Type	Honda GX 160 5.5hp Petrol	Honda GX 120 4.0hp Petrol	Teco 240V 750 Watts Electric
Inlet Hose	20mm (3/4")	20mm (3/4")	20mm (3/4")
Outlet Hose	12.5mm (1/2")	12.5mm (1/2")	12.5mm (1/2")
Max Flow Rate	46 lpm	35 lpm	30 lpm
Max Pressure	1350 kPA	1150 kPA	750 kPA
Dry Weight	20.5 kgs	18.5 kgs	20 kgs
Height	340 mm	320 mm	285 mm
Length	340 mm	330 mm	360 mm
Width	385 mm	340 mm	245 mm

lpm - litres per minute, kPA - kilopascals, kgs - kilograms, mm - millimetres

The manufacturer reserves the right to alter specifications without notice.

## Nova Pumps Start Up Instructions

1. Fill pump body with water (Nova SP Models Only).
2. Connect suction hose from pump inlet (marked with arrow) to supply tank outlet. The suction hose must be of non-collapsible, reinforced construction with a minimum inside diameter of 19mm. Ensure all suction hose connections are airtight otherwise performance may be affected. Keep suction hose as short as possible and avoid unnecessary bends.
3. Connect pressure spray hose from pump outlet (marked with arrow) to spray equipment. Ensure all pressure spray hose connections are airtight otherwise performance may be affected.
4. Connect hose from bypass ball valve to supply tank.
5. Fill supply tank with spraying liquid. (Nova NP Model only - ensure fluid level in supply tank is above highest point of suction hose).
6. Open the bypass ball valve completely, run the pump at slow speed and allow the pump to prime itself (removing air from the system).
7. The unit is now ready for on-going use. Set the bypass ball valve open halfway, this will ensure the mechanical seal is lubricated at all times.

## Nova Pumps Operating Instructions

- Do not run the pump dry as this will cause serious damage to the mechanical seals.
- Nova SP Electric Model - Ensure any extension leads are rated at 15 amp or greater and are not coiled during use.
- Do not allow foreign materials to be pumped such as grit, sand or other abrasives as this will cause premature wear of the pump. Check the bottom of your supply tank regularly.
- For infrequent use and before long periods of storage, flush and drain the pump thoroughly. For engine storage instructions refer to the manufacturers Owners Manual.
- If frost or freezing conditions are likely to occur drain all liquids to prevent damage from freezing liquid expanding within the pump.
- Regularly check the pump drainage hole, located on the motor flange, for leaks and replace the mechanical seals if necessary.
- To ensure optimum performance it is recommended that the pump's mechanical seals are replaced between seasons.
- To prevent deposits forming and damaging the pump it is recommended that the pump is flushed and cleaned on a daily basis.

## Nova Pumps Seal Kit Replacement Guide

It is strongly recommended that the tank is emptied and the pump is flushed with water before dismantling. For safety reasons gloves must be worn during the seal kit replacement procedure.

Before dismantling the pump, mark all components in their fitted positions for reassembly.

### Recommended tools and equipment

#### All models

- Adjustable wrench spanner
- 7/16" spanner
- 10mm spanner
- Flathead screwdriver
- Hammer
- Grease
- Wet and dry fine emery paper
- Cloth

#### Additional tools for petrol engine models

- 13/16" spark plug spanner
- 1/2" spanner
- Pipe wrench

#### Additional tools for electric motor models

- Phillips/star head screwdriver
- 13mm spanner

### Steps for replacement of seal kit

#### Dismantling of pump

1. Petrol engine models - using the 13/16" spark plug spanner, remove the spark plug. Using the 10mm spanner, remove the recoil starter to expose the recoil hub. Electric motor models - use the Phillips/star head screwdriver to remove the fan cover.
2. Using the 7/16" spanner, remove the four pump body screws (position 12). Using the hammer from behind the pump body (position 1), tap loose and remove the pump body exposing the impeller (position 2).

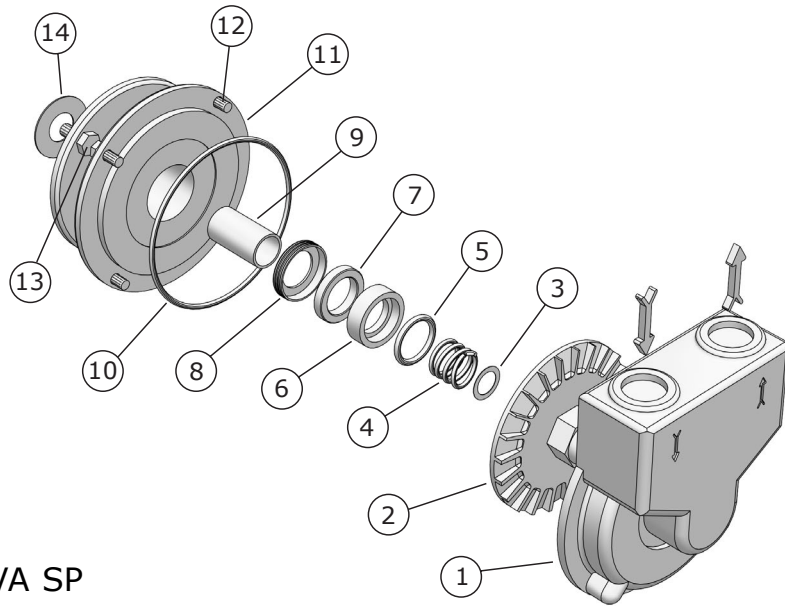

NOVA SP

POSITION NUMBER	DESCRIPTION
1	Pump Body - Bronze
2	Impeller - Bronze
3	Shim - Brass
4	Spring - S/Steel
5	O-ring - Viton
6	Seal - Carbon
7	Washer - Ceramic/SiC
8	Boot - Viton
9	Shaft Sleeve - S/Steel
10	O-ring - Nitrile
11	Motor Flange - Bronze
12	Screws - Steel
13	Screws - Steel
14	Washer - Teflon

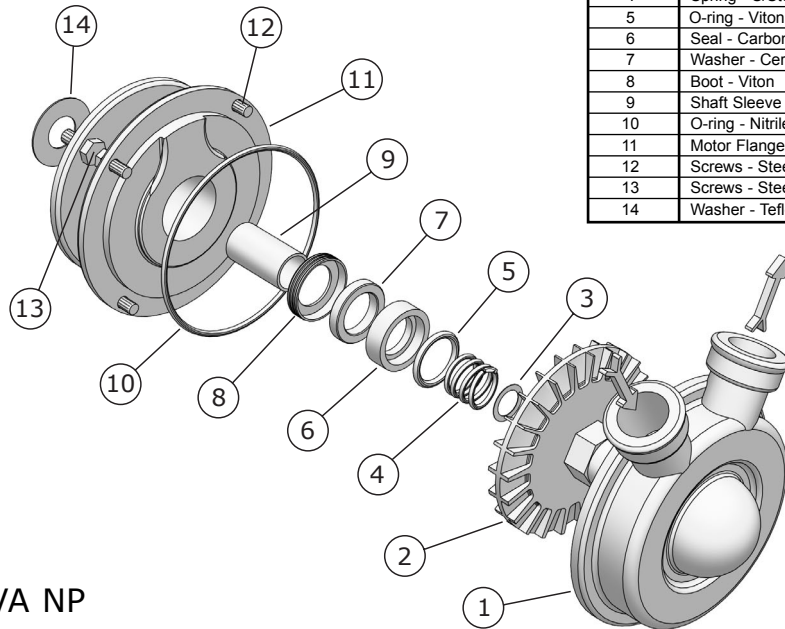

NOVA NP

3. Petrol engine models - use the pipe wrench to secure the recoil hub, taking care not to damage the recoil hub.  
Electric motor models - use the 10mm spanner to secure the rear of the shaft.
4. Using the adjustable wrench spanner on the hex nut of the impeller, turn the impeller anti-clockwise then remove it from the shaft. Remove any shim or shims (position 3) fitted between the shaft and the impeller and retain for reassembly.
5. Petrol engine models - use the 1/2" spanner. Electric motor models - use the 13mm spanner. Remove the four motor flange screws (position 13). Using the Flathead Screwdriver gently remove the motor flange (position 11) from the motor. For Nova NP models remove any shim or shims fitted between the motor flange and the motor and retain for reassembly.
6. Place the motor flange, impeller side down, on a bench. Place the spark plug spanner or a screwdriver in the central hole against the rear of the Viton boot (position 8) and tap gently with a hammer to remove both the Viton boot and the Ceramic/SiC washer (position 7). Remove and discard all seal components.
7. Use a cloth to thoroughly clean all pump components. Use wet and dry emery paper to polish the motor flange bore and then lubricate with grease.

#### Reassembly of pump and new seal components

8. Place the motor flange, impeller side up, on a bench. Place the Ceramic/SiC washer with the Viton boot, polished side facing up, in the motor flange bore and push firmly into position against the shoulder. Use a cloth to remove any excess grease from the bore and Ceramic/SiC washer.
9. Use a cloth and wet and dry emery paper to clean and polish the motor shaft.
10. Place motor flange against the motor in its original position with the drain hole pointing in a downward direction, do not dislodge the Ceramic/SiC washer and Viton boot from their positions. Replace any shim or shims between the motor and the motor flange. Replace the screws connecting the motor flange to the motor and tighten evenly.
11. Ensure surfaces of the Carbon seal (position 6) and the Ceramic/SiC washer are clean and free of foreign materials. With the polished surface facing inwards, place the Carbon seal on the motor shaft and push into position against the Ceramic/SiC washer.

12. Place the Viton O-ring (position 5) on the motor shaft behind the Carbon seal and push the O-ring into the recess of the Carbon seal taking care not to damage the O-ring.
13. Replace the shim or shims removed during step 4 on the motor shaft.
14. Ensure the spring (position 4) is fitted to the impeller with the spring locator in position in the impeller locating hole.
15. Petrol engine models - use the pipe wrench to secure the recoil hub, taking care not to damage the recoil hub.  
Electric motor models - use the 10mm spanner to secure the rear of the shaft.
16. Place the impeller on the shaft. Using the adjustable wrench spanner on the hex nut of the impeller, turn the impeller clockwise and tighten firmly. The impeller should just touch the motor flange and rotate freely when turned.
17. Place the Nitrile O-ring (position 10) around the motor flange.
18. Replace the pump body in its original position on the motor flange and replace and tighten the pump body screws. For Nova NP models the motor flange bridge must align with the pump body bridge.
19. Petrol engine models - replace the spark plug and recoil starter.  
Electric motor models - replace the fan cover.
20. The Nova Pump is now ready for use. Refer to the Nova Pumps Start Up Instructions before operation.

## Trouble Shooting Guide

Problem	Cause	Solution
Pump Leaking	Mechanical seal failure	Replace mechanical seal - see Seal Kit Instructions
	Pump body cracked	Refer to dealer
Fittings Leaking	Loose or broken fittings	Remove and reseal or replace fittings
No or Low Output	Suction hose clogged or improper size	Clear obstruction from suction hose or replace with correct hose size
	Suction hose collapsed	Replace suction hose
	Air leak from inlet plumbing	Check hoses and connections are airtight, replace if necessary
	Pump not primed	Prime pump - see Start up Instructions
	Pump ports blocked	Clear obstruction from pump ports
	Output hose or fittings blocked	Clear obstruction from output hose or fittings
	Output hose collapsed	Replace output hose
	Output hose or fittings leaking	Check and reseal or replace output hose or fittings
	Worn pump components	Replace pump - refer to dealer
	Impellor not rotating	Refer to dealer
Low engine performance	Refer to Engine Manufacturers Owners Manual.	



[www.novapumps.com.au](http://www.novapumps.com.au)